

- (E) Double faced infoboard is designed as a light box. Height is 1760 mm and the width of the box is 110 mm mitred corner. Acrylic shelf can be added if desired.
- (D) Doppelseitiger Infoboard ist als Leuchtkasten entworfen. Höhe und Breite sind 1760x110 mm auf Gehrung geschnitten. Falls erwünscht, können Acrylablagen mitgeliefert werden.
- (I) Infoboard bifacciale retroilluminato. Altezza 1760 mm e spessore della scatola luminosa di 110 mm, angoli a 45°. Da ordinare separatamente i ripiani in acrilico trasparente.

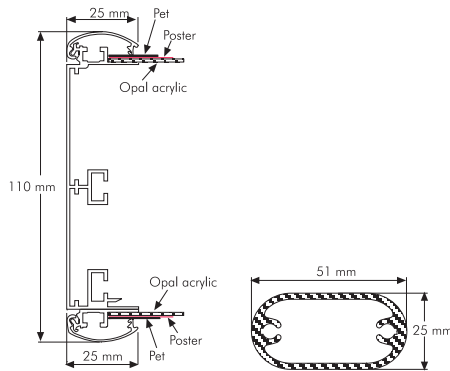

- (E) Product is packed unassembled with an easy mounting instruction sheet & fixing elements.
- (D) Das Produkt wird demontiert mit Montageanweisung und Befestigungselementen verpackt.
- (I) La struttura è imballata non assemblata con istruzioni di montaggio.
- (E) Wheels & shelf are not included in the original pack.
- (D) Die Lenkrollen und Ablagen sind nicht komplett.
- (I) Ruote su richiesta e ripiani da ordinare separatamente.
- ! (E) All units pass CE/UL Pat test, come a long with their certificates. UK plug must be mentioned on order.
- (D) Alle Produkten sind CE/UL Pat getestet, sie sind mit ihren Zertifikaten geliefert. Der UK Stecker muss in der Bestellung genannt werden.
- (I) Tutti i componenti luminosi CE/UL certificati.

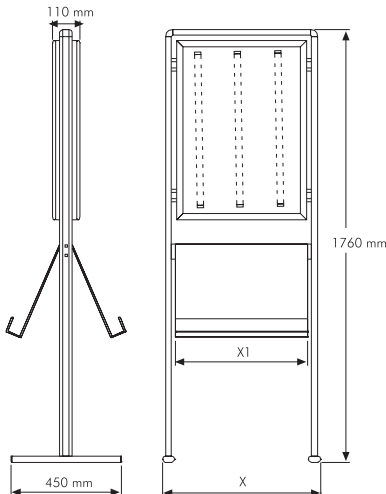

MATERIAL : Silver anodised aluminium					WEIGHT	PACKING SIZE	SHELF : 4 mm acrylic	
DOUBLE SIDED	POSTER	X	X1	LIGHTING	WITH PACKING	*W X H X D	DOUBLE SIDED	CAPACITY
UIB305CNA1	594 X 841 mm	740 mm	440 mm	5 X 15W	14,250 kg	770 X 1780 X 130 mm	UYRC0001A4	2 X A4
UIB305CNB2	500 X 700 mm	646 mm	440 mm	2 X 18 W	13,250 kg	660 X 1780 X 130 mm	UYRC0002A4	4 X A4
UIB305CNB1	700 X 1000 mm	853 mm	660 mm	3 X 30 W	15,500 kg	870 X 1780 X 130 mm	UYRC0003A4	6 X A4



* W:Width H: Height D: Depth